

# Intellectual Perseverance

Sandra Kaplan  
University of Southern California  
LAUSD 2016

# Engage

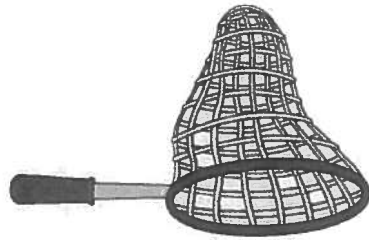

## “Grabbing Attention”

**First**, consider “poking around” the topic to find something of interest.  
**Now**, relate the topic to something you already know and enjoy and explain the relationship.

# Exaggerate

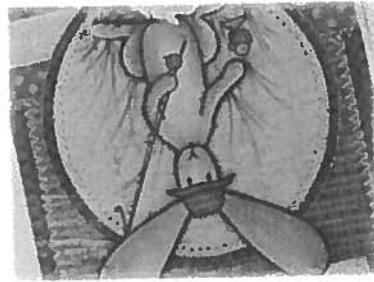

## “Standing Out”

**First**, identify something that is important and valued.  
**Now**, find evidence to support its importance and value.

## “Take a Journey”

First, think about how this topic can lead to a new discovery for you.  
Now, investigate the topic and identify what was learned that was new for you.

# Extend

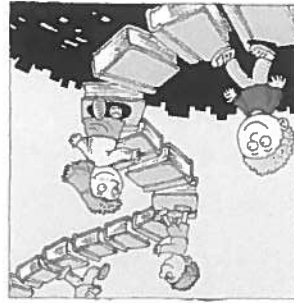

# Excavate



## “Digging Around”

**First**, focus on a part or feature of the topic that is interesting and “new” to you.

**Now**, research a portion or segment of the topic to give it more meaning.

Describe how the story of the topic was a process that caused you to be persistent, task committed, and relevant.

# Stages of Interest/ Stages of Effort

## Stages of INTEREST: An idea and its consequences

1	2	3	4	5
---	---	---	---	---

1	2	3	4	5
---	---	---	---	---

## Stages of EFFORT: An interest and its consequences

Analysis: The relationship between INTEREST and EFFORT.

---

---

---

# OVERCOMING FRUSTRATION

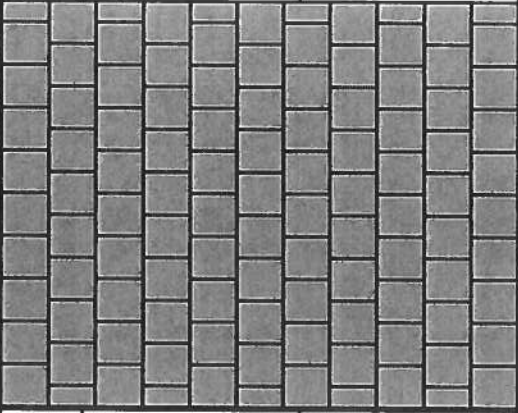
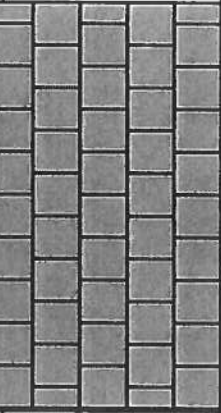
Date	Task	The Wall	What I Did	What I Could Have Done
				
				
				
<p><b>Analysis: What's the pattern of my working style?</b></p>				

# The Intellectual Struggle: Defining Obstacles

Outside the Self:  
Environment

- 1 \_\_\_\_\_
- 2 \_\_\_\_\_
- 3 \_\_\_\_\_
- 4 \_\_\_\_\_

Within the Self:  
Personal

- 1 \_\_\_\_\_
- 2 \_\_\_\_\_
- 3 \_\_\_\_\_
- 4 \_\_\_\_\_



Identify the internal and external obstacles that contribute to the intellectual struggle. Code the obstacles in this biographical sketch.



*How do these thoughts relate to an intellectual struggle?*



<p><b>The Intellectual struggle: A Biography</b></p>
<p>Describe how a person's thoughts contribute to their performance.</p>

# Overcoming Blocks to Reaching a Goal: The Intellectual Struggle

**GOAL**

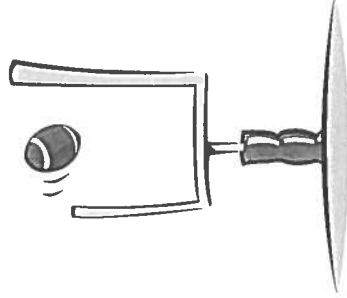

**BLOCK 3**  
Feeling like a failure or guilty for not doing something well or as expected

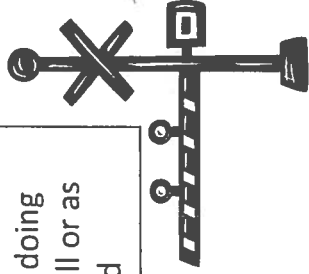

**BLOCK 2**  
Having resources, tools, and time

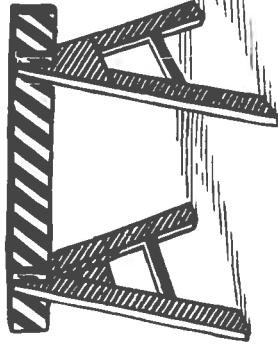

**BLOCK 1**  
Setting priorities to do the task

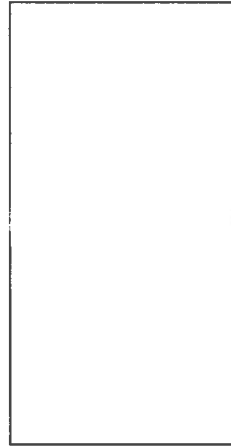
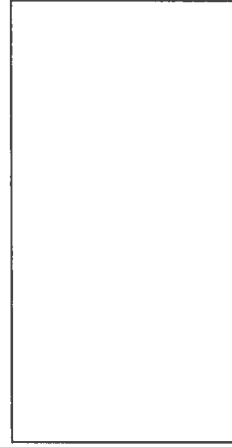
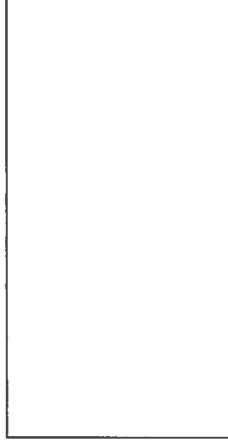
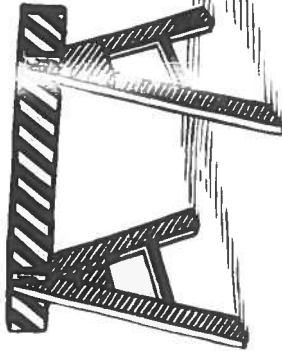

# Genre: Intellectual Struggle

Sample Story	A True Story	My Story
<p>Mina was number 4 in the math competition. She was thinking about how many As and 100s she had earned in math. She knew she could win the competition. The teacher put the equation on the board and told the students in the competition they had ten minutes to get the answer. Mina noticed she had forgotten her watch. How could she tell the time? She was worried and couldn't remember her nines-multiplication tables.</p>		

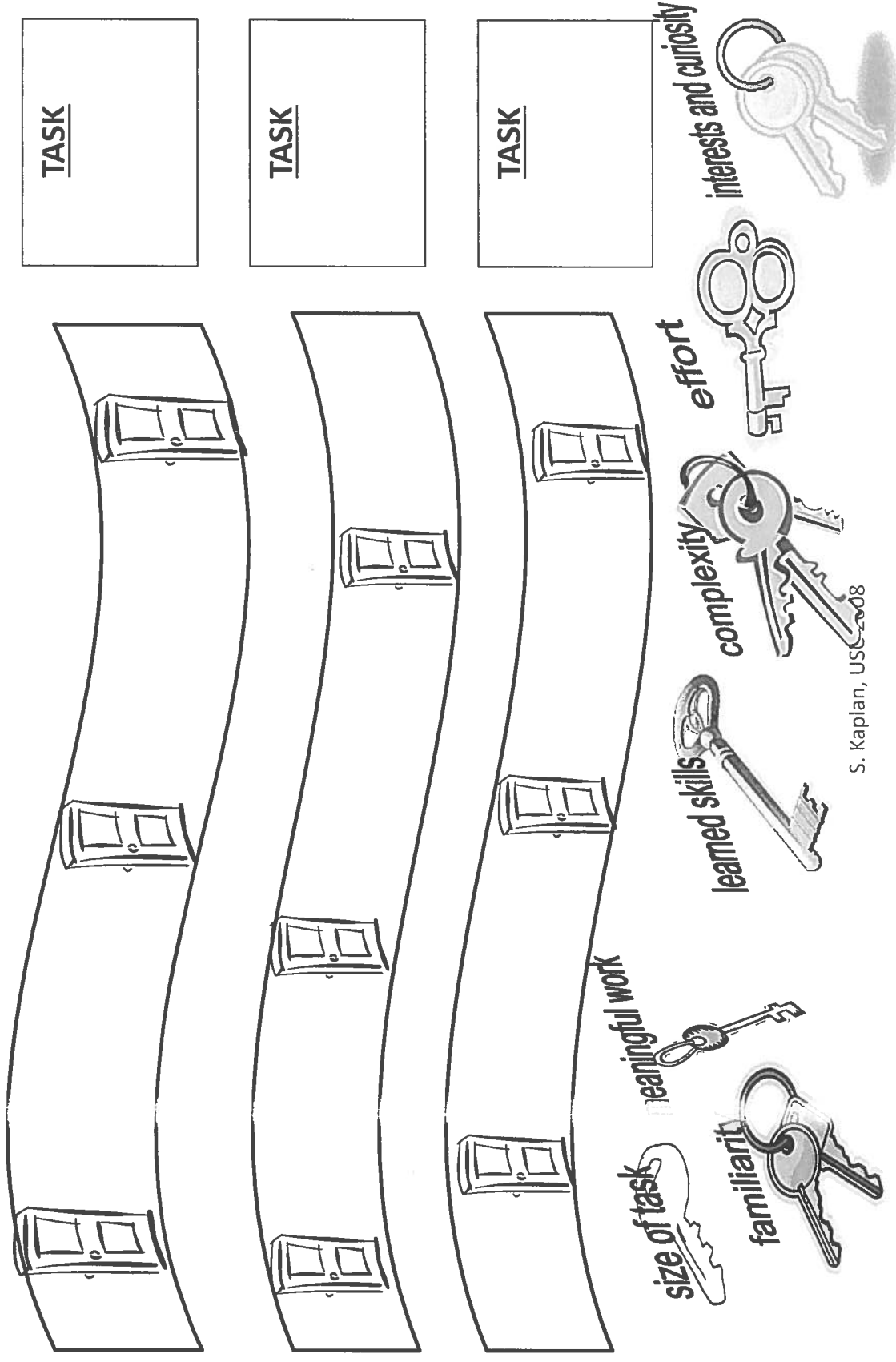

Identify the common features and contributors of Intellectual Struggles.	
Features	Contributions

# Different Tasks: Different Keys to Unlock Doors

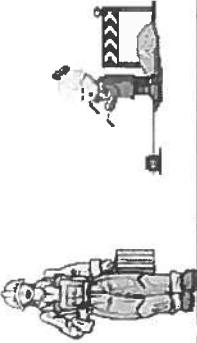

# Product Development

Product:

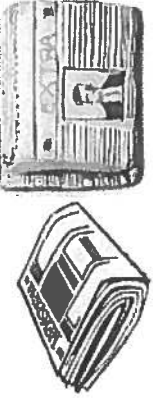

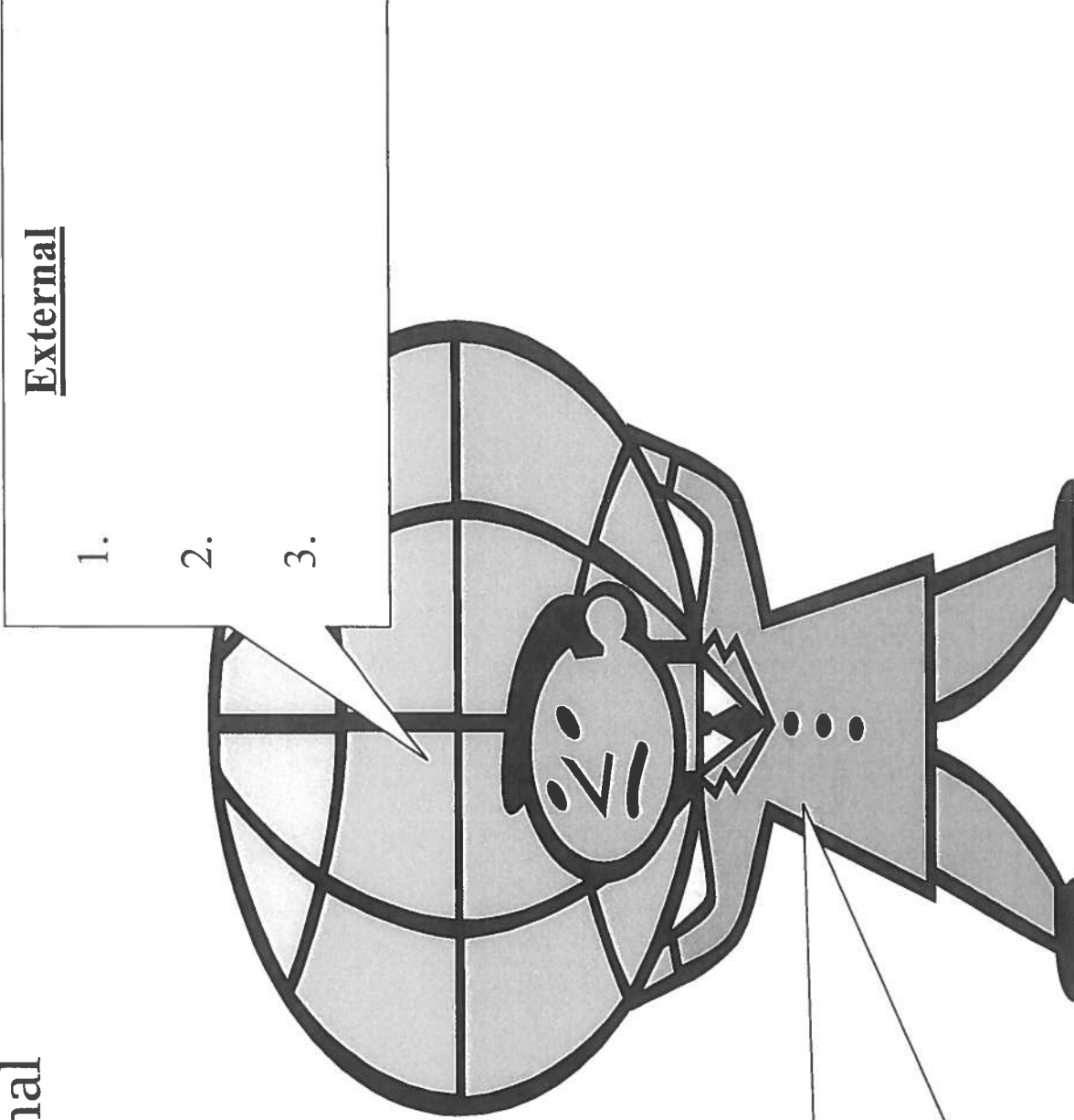

Tools	Skills	Depositions	Contributions
			

# Internal vs. External Criteria to Judge A Product

- Internal**
- 1.
  - 2.
  - 3.
  - 4.



# Productivity Timeline/Graph

Prove or Disprove: “*Quality is more important than quantity*”

Pro	Con



**The Role of Failure: “When you do not succeed try, try again.”**

